

Since 1969

**TOLKAR**<sup>®</sup>  
**SMARTEX**<sup>®</sup>

Technological, Economical, Ecological Differences

**2023 LAUNDRY MACHINES**

Distributor:



**GATEWAY VENTURES FZE**

P6-71, SAIF Zone,

Sharjah, United Arab Emirates

Tel: +971 6 5573850 | Fax: +971 6 5573851

Website: [www.gvhts.com](http://www.gvhts.com) | [info@gvhts.com](mailto:info@gvhts.com)

- Technological,
- Ecological,
- Economical Differences,



*Hydra*



*miracle*  
Hydra



*miracle*  
Hydra



*Carina*  
tumble dryers

# Rising Stars...

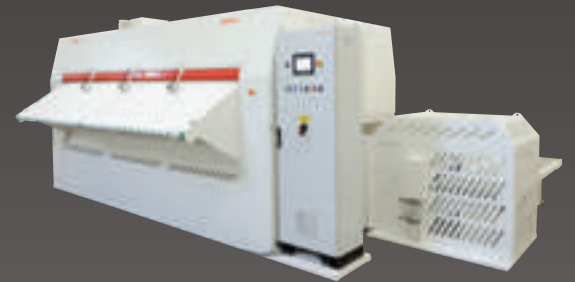



## INDEX

Company Profile .....	6
Tolkar Future Full Automatic Loading Unloading Systems .....	8
Tolkar Carina Pass Through Tumble Dryers .....	10
Full Automatic Washer Extractors .....	11
Hygienic Barrier Type Washer Extractors.....	27
Tumble Dryers.....	30
Stacked Washer Extractors and Dryers Stacked Dryers .....	34
Speed Queen Stacked Washer Extractors / Tumble Dryers.....	35
Flatwork Ironers .....	36
Chest Heated Ironers .....	40
Linen and Towel Folding Machines .....	46
Feeders / Towel Rollers .....	50
Laundry Auxiliary Equipments.....	51
Colmac Automatic Tunnel Ironing Systems.....	53
Distributorships .....	54
Countries We Are Exporting To .....	55

# WORLD'S MOST ADVANCED WASHING TECHNOLOGY

**%100** MEASURABLE  
SUSTAINABLE  
ECONOMICAL & GREEN

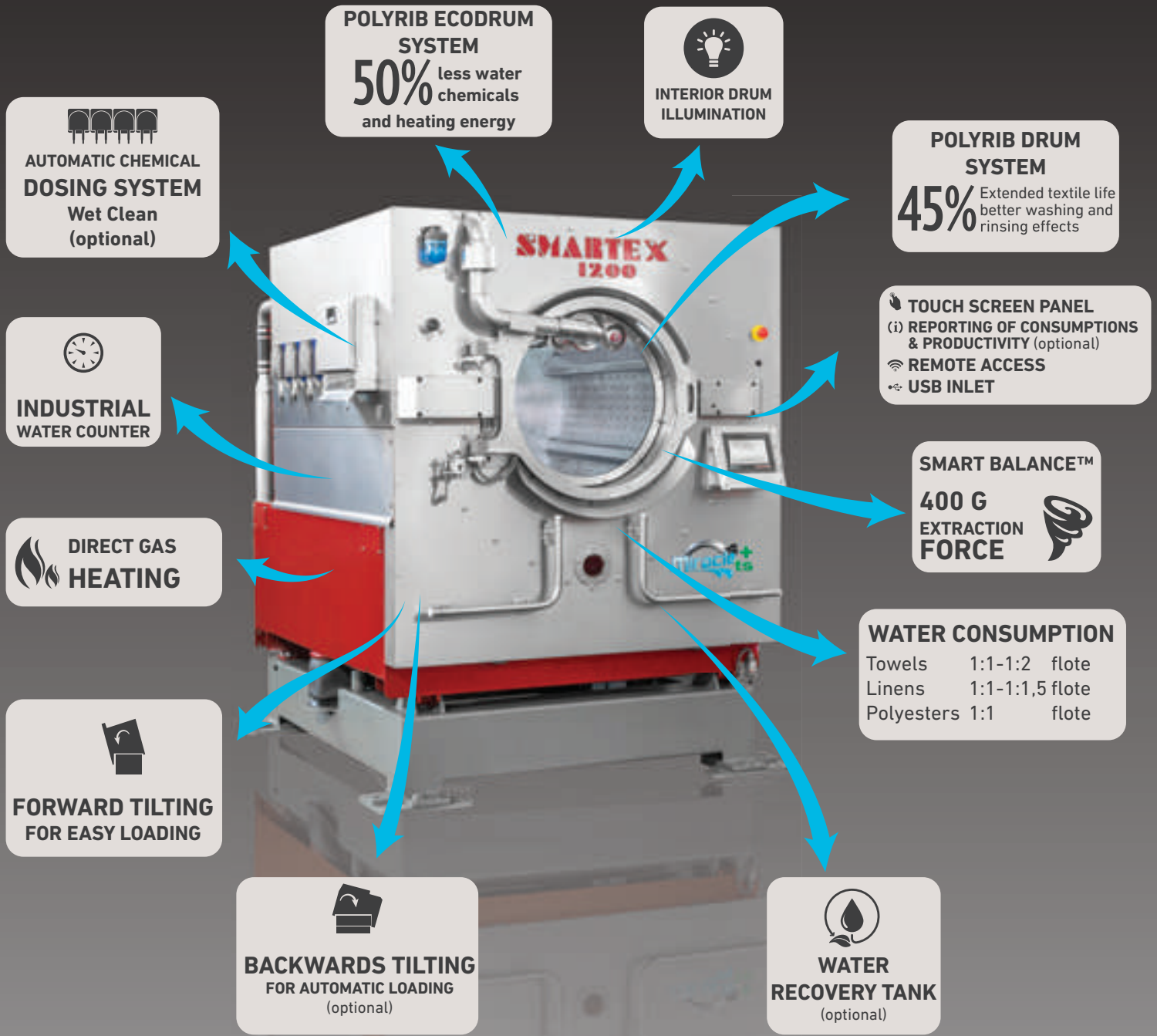



## COMPANY PROFILE

TOLKAR has established in 1969 as a family business regarding to produce textile processing and commercial laundry machines in city of Izmir, TURKEY. From the very first date, continuous development, better quality and customer satisfaction have made up a principle by TOLKAR where at the present day constitutes from 3 splendid innovative production factories in İZMİR Ataturk Industrial Zone, distributorship of the leader manufacturers of their sectors for supplementary products. TOLKAR has its own reputation in the world by reaching the production capacity of 3500 machines per year of various models and exports more than 91 countries abroad. Besides, 18 Regional Branches with their Sales & Service Managements in Turkey TOLKAR has more than 30 distributors with their Sales & Service Managements in abroad, ensures the fastest sales and after sales servicing facilities to their customers.

Along the stage of development, TOLKAR is devoted itself to differ as technological, ecological and economical supremacies. Utilization of latest technologies and techniques in production, TOLKAR performs from starting up the design phase, consequent research & development, prototype production, factory tests, field tests and mass production by accomplishing the mentioned triple mission. All revolutionary inventions those differs as technological, ecological and economical supremacies; have been protected with their Patents in all over the world. All our innovations offer to our customers uncompromisable and inapproachable savings where at the same time minimize the effluent in order to protect the environment for a clean world to the next generations.

TOLKAR provides all capacities of commercial & industrial laundry machines along with auxiliary equipment including turnkey projects and all textile/garment processing, washing, dyeing machines, unique waterless technologies right alongside the distributorship of the leader brands such as BIKO, COLMAC, SPEED QUEEN and RENZACCI.

In 2008, after acquisition of SMARTEX and its patented "Smart Balancing System", TOLKAR becomes the unique company who has the capability of manufacturing very high speed washer extractors by exerting 400 G force while spinning. Yet as the first and the only producer of the unique innovation introduced PolyRib ECO Drum, TOLKAR is proud to offer SMARTEX Miracle series which saves dramatically 50 % from the water, chemicals and heating energy and waste water along with the very first manufacturer of 'Direct Gas Heated' Washer Extractors.

Starting from 2013, TOLKAR announces to work on waterless and chemical free washing and processing technics by concentrating to develop Ozone Washing and Smart Flow Nano Bubble technologies for textile and garment industry in order to achieve dramatic reduction of water as well as to stop heavy chemical wastes. Today dissolution of the ozone gas within the water has achieved by TOLKAR wherein many garment processing steps can be done without chemicals and without any water discharge in shorter times. Same as Smart Flow Nano Bubble Spraying Technology achieves some steps without any water usage and without any discharge to environment.

In 2019, TOLKAR established the unmanned laundry and textile washing facilities with TOLKAR Future within the framework of Automation and Industry 4.0 applications. It has managed to establish an almost unmanned business by controlling all washing, drying, chemical transfer, recipe preparation and reporting from a single center by providing loading/unloading and textile transfers with automatic conveyors and shuttles.

With the consciousness of change alone is unchanging, TOLKAR will perpetuate the leadership in accordance with its mission to next generations.



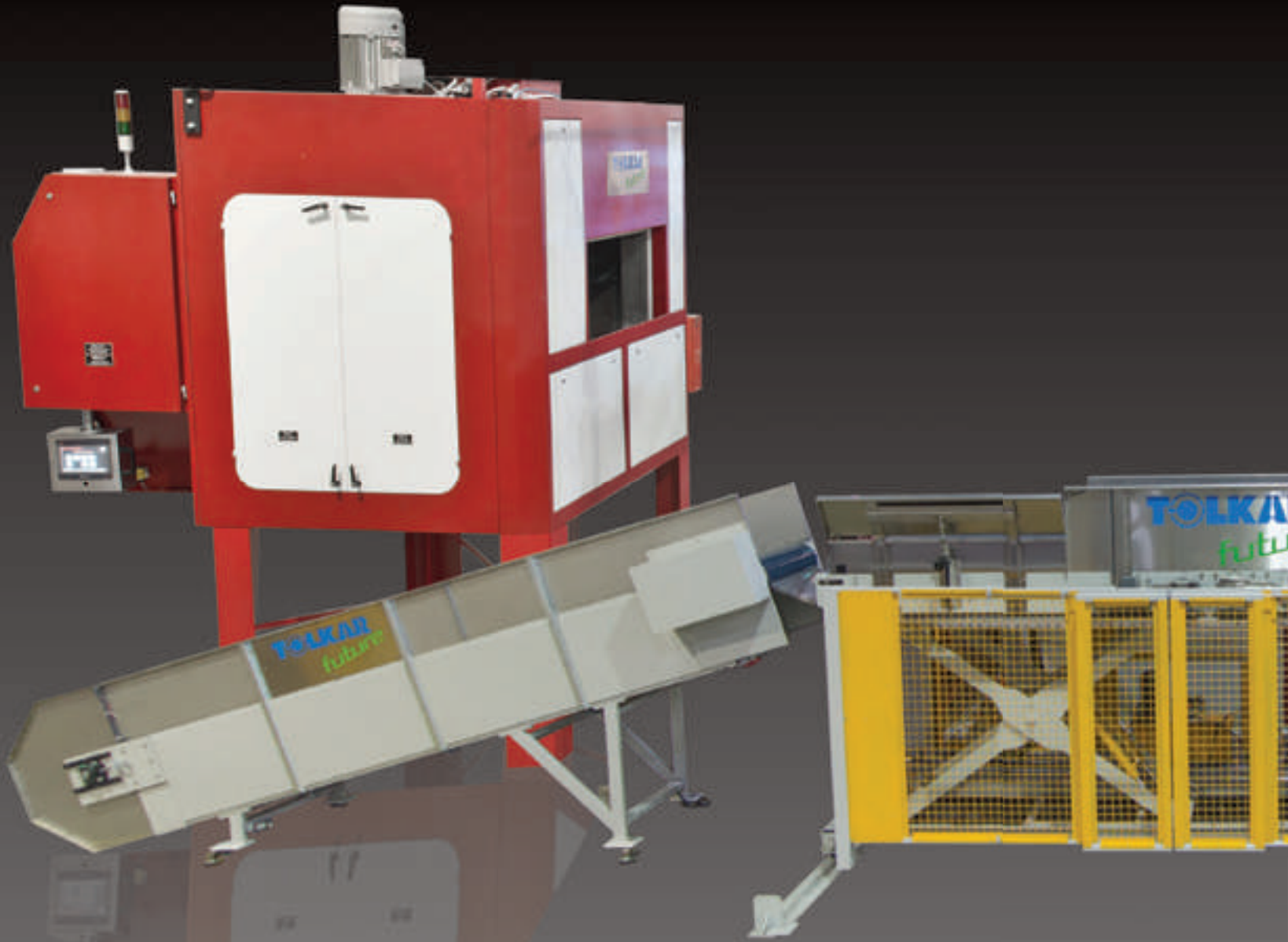

**1000 - 1500 KG/HOUR  
PRODUCTION WITH  
FULL AUTOMATION  
SYSTEM**

**ZERO REJECTION  
WITH MAXIMUM  
CLEANING  
PERFORMANCE**

**SUITABLE FOR  
FLEXIBLE  
WORKING WITH  
STAND BY SYSTEM**

**MAXIMUM  
PRODUCTIVITY  
WITH RAPID  
LOADING &  
UNLOADING**



**TOLKAR FUTURE**  
Automatic Loading Unloading System

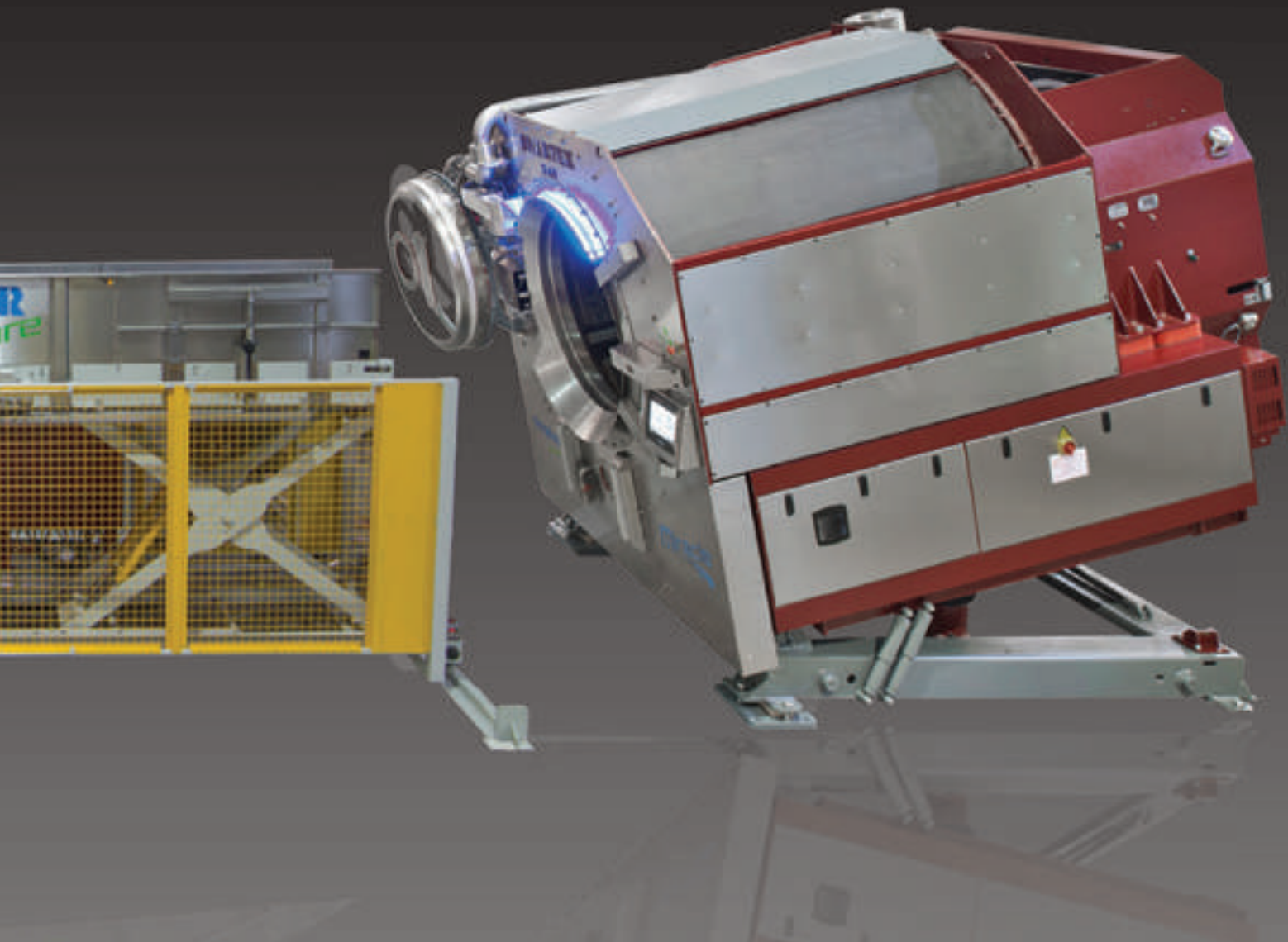

**AUTOMATIC  
LOADING  
UNLOADING  
CONVEYOR &  
SHUTTLE SYSTEM  
ELIMINATES  
THE NEED FOR  
LABOUR 90%**

**CONTROLLED  
FROM  
CENTRALIZED  
COMPUTER  
INCLUDING  
RECIPE  
TRANSFER**

**FULLY MAN  
FREE OPERATION  
ELIMINATES  
THE RISKS OF  
FAILURE  
AND  
MISTAKES**

**MINIMUM  
CHEMICAL  
CONSUMPTION  
WITH  
AUTOMATIC  
CHEMICAL  
DOSING**

**ACCOMPLISHED  
TRANSPORTATION  
CONVEYOR  
BEHIND  
THE DRYERSÍ  
FOR EASY  
TRANSPORT TO  
FINISHING  
(OPTIONAL)**

## TOLKAR CARINA PT

Pass Through Tumble Dryers

150 - 250 Kg



		3000	5000
Heating Type		Steam / Gas	Steam / Gas
Capacity	(Kg)	150	250
Drum Volume	(lt)	3.014	5.070
Drum Diameter	(mm)	1.600	1.980
Drum Depth	(mm)	1.500	1.650
Motor Power	(Kw)	5.5	5.5
Fan Motor Power	(Kw)	11	11
Steam Consumption	(Kg/Hour)	350	500
Gas Heat Power	(Kcal)	99.000	173.250
Air flow	(m <sup>3</sup> /Hour)	11.000	22.000
Width	(mm)	2.200	2.543
Depth	(mm)	2.200	3.079
Height	(mm)	4.000	4.446
Weight	(Kg)	3.000	4.9910

Tolkar reserves changing the technical specifications of the machines due to technological necessities without prior notice

Steam & Gas heated models

Humidity control

Infrared control drying (Optional)



PLC controlled touch screen panel

Front side loading and back side unloading automatically

Compatible with automatic loading unloading systems

Faster drying time within 20-25 min/cycle



**SMARTEX MIRACLE**  
Full Automatic Washer Extractors

225 - 340 Kg

		Miracle 2250	Miracle 3430
Heating Type		Steam / Gas	Steam
Loading Capacity	(Kg/Batch)	225	340
Drum Volume	(lt)	2.280	3.398
Motor Power	(Kw)	30	18,5
Gas Heat Power	(Kcal/hour)	132.000	-
Width	(mm)	1.915 (2.580)	2.175
Depth	(mm)	2.770	2.550
Height	(mm)	2.562	2.730
Tilted Height	(mm)	2.845	3.110
Weight	(Kg)	4.530	6.670

Tank System  
**WATER RECOVERY**  
Technology

**60%**  
**WATER SAVING**

**BACKWARDS TILTING**  
**EASY LOADING & UNLOADING**

**WATER CONSUMPTION**

Towel 1:1-1:2 L/R  
Linen 1:1-1:1,5 L/R  
Polyster 1:1 L/R

**POLYRIB ECODRUM SYSTEM**

**50%** less water  
chemicals  
heating energy

**POLYRIB DRUM**

**45%**  
Longer textiles life

**400G**  
**EXTRACTION FORCE**

**TOTALLY VIBRATION FREE**

**SMARTEX MIRACLE**

Full Automatic Washer Extractors

**WORLD'S MOST ECONOMIC WASHING SYSTEMS**



**Green**  
technology



**FIRST AND THE ONLY  
GAS HEATED  
IN THE WORLD**

**COMPLETE  
STAINLESS STEEL  
BODY AND BASE  
(Optional)**

**WATER  
CONSUMPTION**

Towels	1:1-1:2	L/R
Linens	1:1-1:1,5	L/R
Polyesters	1:1	L/R

**POLYRIB ECODRUM  
SYSTEM**

**50%** less water  
chemicals  
and heating energy

**POLYRIB DRUM**

**45%**  
Longer  
Textile Life

**SMART  
BALANCING™**

**20%**  
Less drying  
time &  
drying energy

# SMARTEX MIRACLE

Full Automatic Washer Extractors



**400G**

**EXTRACTION FORCE**

**TOTALLY VIBRATION FREE**

## TOLKAR ULTIMATE CONTROL SYSTEM

- Remote access**, instant mobile tracking
- USB programme transfer**
- **20 ready recipes, 100 recipes**
- Reporting**, amount of laundry, consumption values and working hours are being reported. (Optional)
- **SmarteYE centralized control and data acquisition** (Optional)



**PLC Controlled**  
7" Touch Screen Panel

10" Touch Screen Panel for 225&340 models



**Automatic Liquid Detergent Dosing System**

in built dosing pumps for liquid detergent dosing. Integrated with reporting and weight scale systems (Wet Clean) - (Optional)

## SMARTEX MIRACLE

Full Automatic Washer Extractors



		Miracle 600	Miracle 1200
<b>Heating Type</b>		Elc/Stm/Gas	Steam / Gas
Loading Capacity	(Kg/Batch)	60	120
Drum Volume	(lt)	550	1.125
Motor Power	(Kw)	7,5	18,5
Gas Heat Power	(Kcal/hour)	33.000	66.000
Electric Heating Power	(Kw)	40	-
Width	(mm)	1.260	1.530
Depth	(mm)	1.890	2.415
Height	(mm)	1.765	2.030
Tilted Height	(mm)	-	2.370
Weight	(Kg)	1.290	2.230

Tolkar reserves changing the technical specifications of the machines due to technological necessities without prior notice

# SMARTEX MIRACLE

Full Automatic Washer Extractors



		Miracle 1350	Miracle 1500
<b>Heating Type</b>		Steam / Gas	Steam / Gas
Loading Capacity	(Kg/Batch)	135	150
Drum Volume	(lt)	1.300	1.480
Motor Power	(Kw)	18,5	22
Gas Heat Power	(Kcal/hour)	66.000	66.000
Width	(mm)	1.585	1.750
Depth	(mm)	2.448	2.480
Height	(mm)	2.056	2.120
Tilted Height	(mm)	2.456	2.461
Weight	(Kg)	2.700	2.980

Tolkar reserves changing the technical specifications of the machines due to technological necessities without prior notice

**SMARTEX MIRACLE**  
Full Automatic Washer Extractors



		Miracle 2250	Miracle 3430
Heating Type		Steam / Gas	Steam
Loading Capacity	(Kg/Batch)	225	340
Drum Volume	(lt)	2.280	3.398
Motor Power	(Kw)	30	18,5
Gas Heat Power	(Kcal/hour)	132.000	-
Width	(mm)	1.915 (2.580)	2.175
Depth	(mm)	2.770	2.550
Height	(mm)	2.562	2.730
Tilted Height	(mm)	2.845	3.110
Weight	(Kg)	4.530	6.670

**DUST MATS & MOPS**

- Sand separator
- Cyclone filter, self cleanable
- Laser check for tracing the mats
- Compatible with auto loading / unloading systems

**BACKWARDS TILTING**  
Easy Loading & Unloading (optional)

Tolkar reserves changing the technical specifications of the machines due to technological necessities without prior notice



**SMARTEX MIRACLE+TS**  
Full Automatic Washer Extractors

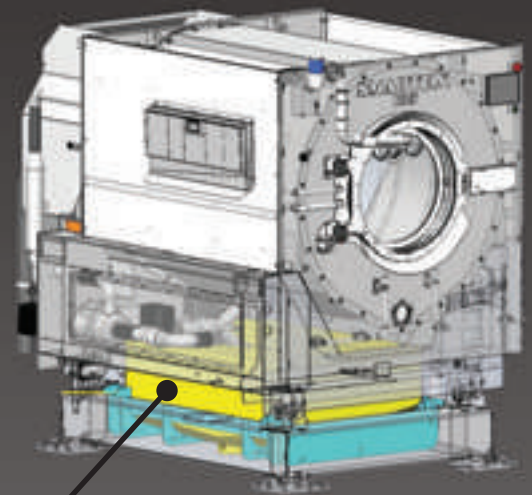

Water recovery tank

**Tank System  
WATER RECOVERY  
Technology**

**60%  
WATER  
SAVING**

		Miracle 600	Miracle 1200	Miracle 1350	Miracle 1500	Miracle 2250
<b>Heating Type</b>		Elc/Stm/Gas	Steam/Gas	Steam/Gas	Steam/Gas	Steam/Gas
Loading Capacity	(Kg/Batch)	60	120	135	150	225
Drum Volume	(lt)	550	1.125	1.300	1.480	2.280
Recovery Tank	(lt)	180	360	400	450	700
Motor Power	(Kw)	7,5	18,5	18,5	22	30
Gas Heat Power	(Kcal/hour)	33.000	66.000	66.000	66.000	132.000
Electric Heating Power	(Kw)	40	-	-	-	-
Width	(mm)	1.260	1.530	1.585	1.750	1.915 (2.580)
Depth	(mm)	1.890	2.415	2.448	2.480	2.770
Height	(mm)	1.765	2.030	2.056	2.120	2.562
Tilted Height	(mm)	-	2.370	2.456	2.461	2.845
Weight	(Kg)	1.290	2.230	2.700	2.980	4.530

Tolkar reserves changing the technical specifications of the machines due to technological necessities without prior notice

## HYDRA Mini Midi Maxi

Full Automatic Washer Extractors



**360 G  
EXTRACTION  
FORCE**

**100%  
HEAVY INDUSTRIAL  
CONSTRUCTION**

- ST37 balance weight system
- Engineered front & rear plates and drum construction
- Enhanced new belt-pulley system and bearing housing
- Unwelded inner drum

**POWERSPRAY**  
(Optional)

**35%** less rinsing water



**25%** less rinsing time

# HYDRA Mini Midi Maxi

Full Automatic Washer Extractors



## TOLKAR ULTIMATE CONTROL SYSTEM

-  Remote access, instant mobile tracking
-  USB programme transfer
- 20 ready recipes, 100 recipes
-  **Reporting**, amount of laundry, consumption values and working hours are being reported. (Optional)
- **SmarteYE** centralized control and data acquisition (Optional)

## FULLY STAINLESS STEEL

inner & outer drums,  
front, sides and  
top covers



**PLC  
Controlled  
7" Touch Screen  
Panel**



## Automatic Liquid Detergent Dosing System

in built dosing pumps for liquid detergent dosing. Integrated with reporting and weight scale systems (Wet Clean) - (Optional)

## HYDRA Mini

Full Automatic Washer Extractors

10 - 12 - 20 - 25 - 30 Kg



		Hydra Mini 10	Hydra Mini 12	Hydra Mini 20	Hydra Mini 25	Hydra Mini 30
Loading Capacity	(Kg/Batch)	10	12	20	25	30
Drum Volume	(lt)	100	120	208	254	300
Motor Power	(Kw)	1.5	2.2	3	4	4
Heating Power	(Kw)	6	8	9	12	15
Width	(mm)	825	825	990	990	990
Depth	(mm)	860	970	1.030	1.155	1.300
Height	(mm)	1.300	1.300	1.450	1.450	1.450
Weight	(Kg)	350	390	595	700	700

Tolkar reserves changing the technical specifications of the machines due to technological necessities without prior notice



## HYDRA Midi

Full Automatic Washer Extractors

40 - 50 Kg



		Hydra Midi 40	Hydra Midi 50
Loading Capacity	(Kg/Batch)	40	50
Drum Volume	(lt)	400	500
Motor Power	(Kw)	5.5	7.5
Heating Power	(Kw)	18	24
Width	(mm)	1.180	1.180
Depth	(mm)	1.345	1.525
Height	(mm)	1.780	1.780
Weight	(Kg)	1.125	1.230

Tolkar reserves changing the technical specifications of the machines due to technological necessities without prior notice

## HYDRA Maxi

Full Automatic Washer Extractors

60 Kg



**Hydra  
Maxi 60**  
Steam/Elc.

Loading Capacity	(Kg/Batch)	<b>60</b>
Drum Volume	(lt)	<b>586</b>
Motor Power	(Kw)	<b>7,5</b>
Heating Power	(Kw)	<b>36</b>
Width	(mm)	<b>1.700</b>
Depth	(mm)	<b>1.560</b>
Height	(mm)	<b>1.920</b>
Weight	(Kg)	<b>1.900</b>

Tolkar reserves changing the technical specifications of the machines due to technological necessities without prior notice

**Wider Loading Door**

**Faster Heating with  
Enhanced Steam Inlet (3/4"i)**

**Faster Water Intake with  
Enhanced Water Inlet (1"i)**

**Double Drain System (2"i)**

**360 G  
EXTRACTION  
FORCE**





# HYDRA Maxi

Full Automatic Washer Extractors

60 Kg



## TOLKAR ULTIMATE CONTROL SYSTEM

-  Remote access, instant mobile tracking
-  USB programme transfer
- 20 ready recipes, 100 recipes
-  **Reporting**, amount of laundry, consumption values and working hours are being reported. (Optional)
- **Smarteye** centralized control and data acquisition (Optional)

Fully Stainless Steel Inner & Outer Drum

New Generation Enhanced Main Shaft and Sealing

Fully Stainless Steel Covers



PLC Controlled  
7" Touch Screen Panel

New Generation Heavy Industrial Construction

New Generation Enhanced Drive System and Bearing Housing

## HYDRA Maxi

Full Automatic Washer Extractors

110 Kg



Hydra  
Maxi 110  
Steam

Loading Capacity	(Kg/Batch)	<b>110</b>
Drum Volume	(lt)	<b>1.100</b>
Motor Power	(Kw)	<b>15</b>
Heating Power	(Kw)	<b>60</b>
Width	(mm)	<b>1.875</b>
Depth	(mm)	<b>2.055</b>
Height	(mm)	<b>2.060</b>
Tilted Height	(mm)	<b>2.265</b>
Weight	(Kg)	<b>4.300</b>

**Wider Loading Door**

**Faster Heating with  
Enhanced Steam Inlet (1î)**

**Faster Water Intake with  
Enhanced Water Inlet (2î)**

**Double Drain System (4î)**



**FORWARD  
TILTING FOR  
EASY  
UNLOADING**

**360 G**

**EXTRACTION  
FORCE**

Tolkar reserves changing the technical specifications of the machines due to technological necessities without prior notice







**HYDRA Maxi**  
Full Automatic Washer Extractors

110 Kg



**TOLKAR ULTIMATE CONTROL SYSTEM**

-  Remote access, instant mobile tracking
-  USB programme transfer
- **20** ready recipes, **100** recipes
- (i)** **Reporting**, amount of laundry, consumption values and working hours are being reported. (Optional)
- **SmarteYE** centralized control and data acquisition (Optional)

Fully Stainless Steel Inner & Outer Drum

New Generation Enhanced Main Shaft and Sealing

Fully Stainless Steel Covers



**PLC Controlled**  
7" Touch Screen Panel

**New Generation Heavy Industrial Construction**

**New Generation Enhanced Drive System and Bearing Housing**

## TOLKAR MIRACLE

Full Automatic Washer Extractors

50 - 60 Kg



**Green technology**

**PLC Controlled**  
7" Touch Screen Panel

**WATER CONSUMPTION**

Towels	1:1-1:2	L/R
Linens	1:1-1:1,5	L/R
Polyesters	1:1	L/R

**POLYRIB ECODRUM SYSTEMS**

**50%** less water chemicals and heating energy

**FULLY STAINLESS STEEL**

Inner & Outer Drums and Covers

**FIRST AND THE ONLY GAS HEATED IN THE WORLD**

		Miracle 50	Miracle 60
Heating Type		Elc/Stm/Gas	Elc/Stm/Gas
Loading Capacity	(Kg/Batch)	50	60
Drum Volume	(lt)	500	600
Motor Power	(Kw)	7,5	11
Gas Heat Power	(Kcal/hour)	33.000	33.000
Electric Heating Power	(Kw)	24	36
Width	(mm)	1.610	1.850
Depth	(mm)	1.525	1.590
Height	(mm)	1.780	2.130
Weight	(Kg)	1.350	2.600

\* All specifications and features of Hydra Series will come along with Tolkar Miracle as standard.

Tolkar reserves changing the technical specifications of the machines due to technological necessities without prior notice



## NORMA HYGIENE

Hygienic Barrier Type Washer Extractors

20 - 40 - 60 - 90 Kg

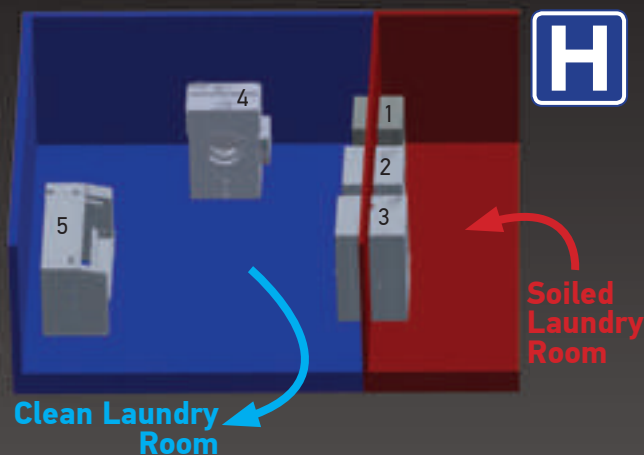

- 1- Norma Hygienic Barrier Type Washer Extractors - 20 kg
- 2- Norma Hygienic Barrier Type Washer Extractors - 40 kg
- 3- Norma Hygienic Barrier Type Washer Extractors - 60 kg
- 4- Carina Tumble Dryer
- 5- Vela Flatwork Ironer

**360 G**  
EXTRACTION  
FORCE

**Green**  
technology

**PLC**  
Controlled  
7" Touch  
Screen Panel

**FULLY STAINLESS STEEL**  
Inner & Outer Drums, Front,  
Sides and Top Covers

**100% HEAVY INDUSTRIAL**  
**CONSTRUCTION**

**TOLKAR ULTIMATE**  
**CONTROL SYSTEM**

- Remote access**, instant mobile tracking
- USB programme transfer**
  - 20 ready recipes, 100 recipes
- Reporting**, amount of laundry, consumption values and working hours are being reported. (Optional)
  - **Smarteye** centralized control and data acquisition (Optional)

		Norma Hygiene 20	Norma Hygiene 40	Norma Hygiene 60	Norma Hygiene 90	Norma Hygiene 120
Loading Capacity	(Kg/Batch)	20	40	60	90	120
Drum Volume	(lt)	200	400	600	900	1200
Motor Power	(Kw)	3	5,5	11	15	22
Heating Power	(Kw)	9	18	36	45	45
Width	(mm)	1.439	1.540	2.005	1.921	2.360
Depth	(mm)	967	1.161	1.450	1.382	1.450
Height	(mm)	1.590	1.737	1.996	2.171	2.060
Weight	(Kg)	785	1.190	1.600	2.200	2.750

\* All specifications and features of Miracle Series will come along with SMARTEX MIRACLE HYGIENE as standard.

Tolkar reserves changing the technical specifications of the machines due to technological necessities without prior notice

## SMARTEX MIRACLE HYGIENE

Hygienic Barrier Type Washer Extractors

60 Kg



		Miracle Hygiene 600	Miracle Hygiene 1350	Miracle Hygiene 2250
Heating Type		Electric/Steam	Steam/Gas	Steam/Gas
Loading Capacity	(Kg/Batch)	60	135	225
Drum Volume	(lt)	600	1.300	2.280
Motor Power	(Kw)	7,5	18,5	30
Electric Heat Power	(Kcal/hour)	40	-	-
Gas Heat Power	(Kcal/hour)	-	66.000	132.000
Width	(mm)	1.260	1.882	2.355
Depth	(mm)	1.890	2.475	2.770
Height	(mm)	1.765	2.206	2.522
Tilted Height	(mm)	-	2.456	2.692
Weight	(kg)	1.290	2.700	4.650

**FIRST AND THE ONLY GAS HEATED IN THE WORLD**

**PLC Controlled 7" Touch Screen Panel**

**TOLKAR ULTIMATE CONTROL SYSTEM**

- Remote access, instant mobile tracking
- USB programme transfer
- 20 ready recipes, 100 recipes
- (i) Reporting**, amount of laundry, consumption values and working hours are being reported. (Optional)
- Smarteye centralized control and data acquisition (Optional)

\* All specifications and features of Miracle Series will come along with SMARTEX MIRACLE HYGIENE as standard.  
Tolkar reserves changing the technical specifications of the machines due to technological necessities without prior notice

# SMARTEX MIRACLE HYGIENE

Hygienic Barrier Type Washer Extractors

135 - 225 Kg



**400 G**  
EXTRACTION  
FORCE

**DOUBLE**  
CONTROL  
PANEL

**WATER CONSUMPTION**  
Greens 1:1 - 1:2 L/R  
Linens 1 - 1:1,5 L/R  
Uniforms 1:1 - 1:1,5 L/R

**OPEN POCKET**  
SINGLE DRUM

**FIRST AND**  
**THE ONLY**  
**FORWARD TILTING**  
**IN THE WORLD**

**POLYRIB ECODRUM**  
SYSTEM

**50%** less water  
chemicals  
and heating energy

**POLYRIB DRUM**

**45%**  
Longer  
Textile Life

**SMART**  
BALANCING™

**20%**  
Less drying  
time &  
drying energy



**precious**  
**weight**  
**scale system**  
Automatic (only  
required) water,  
steam, chemical intake  
according to scaled  
textiles  
(Optional)

## CARINA

Tumble Dryer Machines



**Green**  
technology



**BIDIRECTIONAL  
ROTATION**



**STAINLESS STEEL  
SERPENTINES**

Resist to high pressure at 10 Bar



**HUMIDITY  
CONTROLLED  
DRYING**



**COOL DOWN**

No more wrinkles,  
hardness and thermal  
shock on textiles



**GAS HEATING**

OPTIONAL IN  
ALL MODELS

**CARINA**  
Tumble Dryer Machines



**GAS + STEAM HEATING SYSTEM**  
(Optional for Models 4069 - 5070)

**FULLY STAINLESS STEEL OUTER CABINET**  
(Optional)

**TOLKAR ULTIMATE CONTROL SYSTEM**

- Remote access, instant mobile tracking
- USB programme transfer
- 10 ready recipes, 100 recipes
- **Reporting**, amount of laundry, consumption values and working hours are being reported. (Optional)
- **Smarteye** centralized control and data acquisition (Optional)

**PLC Controlled**  
7" Touch Screen Panel

**FORWARD TILTING FOR EASY UNLOADING**  
BACKWARDS TILTING FOR EASY LOADING - STANDART  
(Models 2200-4069-5070)  
(Optional for Model 1500)

**INVERTER CONTROLLED ADJUSTABLE DRUM SPEED**

## CARINA

Tumble Dryer Machines

201 - 305 - 405 - 500 - 605 - 805

1000 - 1200 - 1500



		Carina 201	Carina 305	Carina 405	Carina 500	Carina 605	Carina 805	Carina 1000
Heating Type		Electric	Elc./Stm./Gas	Elc./Stm./Gas	Elc./Stm./Gas	Elc./Stm./Gas	Elc./Gas	Elc./Stm./Gas
Capacity 1/20-1/15	(kg)	10/14	15/20	20/27	25/33	30/40	40/53	50/66
Drum Volume	(lt)	201	305	405	500	605	800	1.000
Drum Motor Power	(Kw)	0,37	0,75	0,75	0,75	0,75	1,1	1,1
Fan Motor Power	(Kw)	0,75	0,75	0,75	0,75	0,75/1,5/0,75	1,5	2,2/3/2,2
Electric Heating Power	(Kw)	12	14	14	24,5	21	42	63
Steam Consumption	(Kg/hour)	-	38	38	38	44	-	81
Gas Heat Power	(Kcal/hour)	-	18.000	23.000	23.000	25.000	39.600	39.600
Air flow	(m³/hour)	1.300	1.300	1.300	1.300	1.500	3.900	3.900/4.500/4.500
Width	(mm)	825	970	970	970	1.040	1.040	1.355/1.420/1.360
Depth	(mm)	915	870	1.020/1.100	1.180/1.240/1.240	1.215	1.650	1.500
Height	(mm)	955	1.650/1.780/1.790	1.650/1.780/1.790	1.650/1.780/1.790	1.780/1.860/1.910	1.860	2.130/2.250/2.380
Weight	(kg)	140	280	285	325	365	450	700

Tolkar reserves changing the technical specifications of the machines due to technological necessities without prior notice





## CARINA

Tumble Dryer Machines

2200 - 2700 - 4069 - 5070

		Carina 1200	Carina 1500	Carina 1500*	Carina 2200	Carina 2700	Carina 4069	Carina 5070
<b>Heating Type</b>		Elc./Stm./Gas	Elc./Stm./Gas	Elc./Stm./Gas	Steam/Gas	Steam/Gas	Steam/Gas	Steam/Gas
Capacity 1/20-1/15	(kg)	60/80	75/100	75/100	110/145	135/180	200/270	250/340
Drum Volume	(lt)	1.200	1.500	1.500	2.200	2.700	4.069	5.070
Drum Motor Power	(Kw)	1,5	1,5	1,5	3	3	5,5	5,5
Fan Motor Power	(Kw)	1,5/2,2	2,2/3/3	3/3	4x1,1/2x3	4x1,1/2x3	4x3/2x3	4x3/2x3
Electric Heating Power	(Kw)	63	63	63	-	-	-	-
Steam Consumption	(Kg/hour)	95	110	110	160	270	400	500
Gas Heat Power	(Kcal/hour)	49.500	57.000	57.000	99.000	99.000	148.500	173.250
Air flow	(m <sup>3</sup> /hour)	4.500/6.400/6.400	4.500/6.400/6.400	6.400/6.400	6.400/6.400	11.000	22.000/11.000	22.000/11.000
Width	(mm)	1.355/1.420/1.360	1.355/1.420/1.360	1.800/1.800	2.120/2.000	2.104/2.043	2.240/2.290	2.474/2.489
Depth	(mm)	1.700	2.040	2.240	2.293/2.300	2.415/2.411	2.649/2.704	2.780/2.780
Height	(mm)	2.130/2.250/2.380	2.130/2.250/2.380	2.330/2.650	2.671/2.315	2.742/3.203	3.105/3.321	3.224/3.629
Tilted Height	(mm)		-	2.550/2.650	2.698/3.300	2.808/3.328	3.390/3.699	3.484/3.902
Weight	(kg)	725	900	1.100	1.500	2.300	3.280	3.910

\* with forward tilting option. Tolkar reserves changing the technical specifications of the machines due to technological necessities without prior notice

**CARINA DOUBLEDECK**

Stacked Washer Dryers

**HYDRA DOUBLEDECK**

Stacked Washer Extractors and Dryers Stacked Dryers



10 / 10 Kg



**360 G**  
EXTRACTION  
FORCE



**DIRECT GEAR  
BOX DRIVE  
DRYER**

**100% HEAVY INDUSTRIAL  
CONSTRUCTION**

**FULLY STAINLESS  
STEEL**

Inner & Outer Drums, Front, Sides  
and Top Covers

DOUBLEDECK WASHER			DOUBLEDECK DRYER		
Loading Capacity	(Kg/Batch)	<b>10</b>	Loading Capacity	(Kg/Batch)	<b>10</b>
Drum Volume	(lt)	<b>100</b>	Drum Volume	(lt)	<b>200</b>
Motor Power	(Kw)	<b>1,5</b>	Motor Power	(Kw)	<b>0,25</b>
Heating Power	(Kw)	<b>6</b>	Heating Power	(Kw)	<b>14</b>
Width	(mm)	<b>825</b>	Width	(mm)	<b>825</b>
Depth	(mm)	<b>885</b>	Depth	(mm)	<b>915</b>
Height	(mm)	<b>1.225</b>	Height	(mm)	<b>955</b>
Weight	(Kg)	<b>350</b>	Weight	(Kg)	<b>140</b>

Tolkar reserves changing the technical specifications of the machines due to technological necessities without prior notice

## SPEED QUEEN

Full Automatic Washer and Dryers

10 / 10 Kg



### WASHER

Capacity	(Kg)	<b>10</b>
Drum Volume	(lt)	<b>96.8</b>
Motor	(Kw)	<b>0,67</b>
Electric Heating	(Kw)	<b>4.8</b>
Width	(mm)	<b>680</b>
Depth	(mm)	<b>820</b>
Height	(mm)	<b>1.990</b>
Weight	(Kg)	<b>122</b>

- Stainless steel inner and outer drum
- Shorter washing time
- 6 recipes with electronic control
- Industrial components for longer life time
- 440 G - 1200 Rpm with dynamic balance

### WASHER

Capacity	(Kg)	<b>10</b>
Drum Volume	(lt)	<b>96.8</b>
Max. Extraction	(G force)	<b>440</b>
Motor	(Kw)	<b>0,67</b>
Electric Heating	(Kw)	<b>4.8</b>

### DRYER

Capacity	(Kg)	<b>10</b>
Drum Volume	(lt)	<b>198</b>
Motor	(Kw)	<b>0,25</b>
Electric Heating	(Kw)	<b>5,35</b>
Width	(mm)	<b>683</b>
Depth	(mm)	<b>704</b>
Height	(mm)	<b>1.980</b>
Weight	(Kg)	<b>122</b>

### DRYER

Capacity	(Kg)	<b>10</b>
Drum Volume	(lt)	<b>198</b>
Motor	(Kw)	<b>0,25</b>
Electric Heating	(Kw)	<b>5.35</b>
Width	(mm)	<b>683</b>
Depth	(mm)	<b>711</b>
Height	(mm)	<b>1.092</b>
Weight	(Kg)	<b>61</b>

- High performance with exhaust ducting
- Shorter drying time with higher resistance power
- 5 programmes with electronic control
- Industrial components for longer life time
- Wide lint filter
- 180°C opening loading door

**COIN OR CARD OPERATED**  
(Optional)

## VELA

Flatwork Ironers



**NON MARKING  
WITH DOUBLE  
MAIN BELT  
SYSTEM**

(Optional)

**Green  
technology**

  
**GAS HEATING**  
OPTIONAL IN ALL  
MODELS

  
**PADDLE BOX & FAN  
SYSTEM**  
FOR HUMIDITY COLLECTION  
AND DISCHARGE IN  
ALL MODELS

**GENUINE  
NOMEX  
BELTS**

**STAINLESS  
STEEL  
MAIN ROLL**

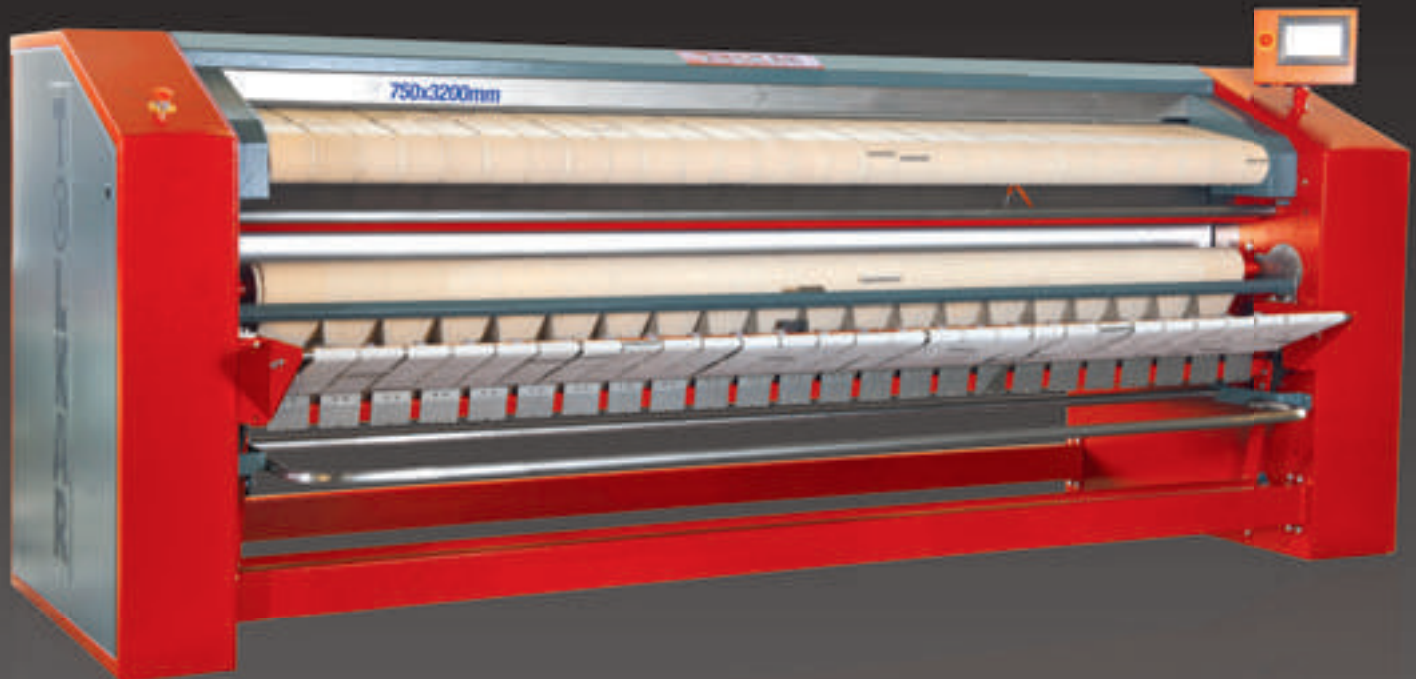

(Optional)

**VELA**  
Flatwork Ironers



  
**IN BUILT FOLDING**  
Vela 7532 model offers 2 - 8 primary folds between 30 - 50 cm length

**TOLKAR ULTIMATE CONTROL SYSTEM**

-  Remote access, instant mobile tracking
-  USB programme transfer
- 5 ready recipes, 100 recipes
-  Reporting, amount of laundry, consumption values and working hours are being reported. (Optional)
- Smarteye centralized control and data acquisition (Optional)

  
**PLC Controlled**  
7" Touch Screen Panel  
(Standard in Vela 7532)  
(Optional)

  
**ACCORDING TO TEXTILE TYPES**  
**VELOCITY CONTROLLED ROLLS**  
(Standard in Vela 7532)  
(Optional)

**AUTOMATIC TEXTILE LENGTH MEASUREMENT**  
(Standard in Vela 7532)  
(Optional)

## VELA

Flatwork Ironers

320 - 500 - 550 - 650 mm  
Roll Diameter



		Vela 3218	Vela 5520	Vela 5525	Vela 5530	Vela 5532 
Heating Type		Electric	Elc./Steam/Gas	Elc./Steam/Gas	Elc./Steam/Gas	Elc./Steam/Gas
Cylinder Diameter	(mm)	320	550	550	550	550
Cylinder Width	(mm)	1.800	2.000	2.500	3.000	3.200
Ironing Capacity	(Kg/hour)	30-35	65-75	85-105	90-120	90-120
Working Speed	(m/min)	2-6	3,5/10,5	3,5/10,5	3,5/10,5	3/9
Motor Power	(Kw)	0,37	1,1	1,1	0,55/0,55/1,1	0,55/0,55/1,1
Fan Motor Power	(Kw)	0,37	0,37	0,37	0,37/0,37/2x0,37	0,37/0,37/2x0,37
Elec. Heating Power	(Kw)	12	22,5	27	31,5	31,5
Steam Consumption	(Kg/hour)	-	45	50	55	55
Gas Heat Power	(Kcal/hour)	-	26.350	28.900	31.570	31.570
Width	(mm)	2.385	2.589/2.823/2.966	3.089/3.323/3.466	3.589/3.823/3.966	3.930/3.930/4.090
Depth	(mm)	1.012	1.196/1.196/1.334	1.196/1.196/1.334	1.196/1.196/1.334	1.150/1.200/1.200
Height	(mm)	992	1.523/1.523/1.569	1.523/1.523/1.569	1.523/1.523/1.569	1.355/1.355/1.675
Weight	(Kg)	500	930	1.050	1.170	1.360

Tolkar reserves changing the technical specifications of the machines due to technological necessities without prior notice

Capacities are given for the laundry extracted at 300 G force.

It is recommended that textiles keeping more water and moisture due to thickness or knit raw material should be pre dried in the dryers before ironing.



		Vela 7520	Vela 7525	Vela 7530	Vela 7532 	Vela 9530	Vela 12030
Heating Type		Elc./Steam/Gas	Elc./Steam/Gas	Elc./Steam/Gas	Elc./Steam/Gas	Elc./Steam/Gas	Elc./Steam/Gas
Cylinder Diameter	(mm)	750	750	750	750	950	1.200
Cylinder Width	(mm)	2.000	2.500	3.000	3.200	3.000	3.000
Ironing Capacity	(Kg/hour)	80-100	90-120	120-150	100-130	160-200	200-250
Working Speed	(m/min)	4,5/13,5	4,5/13,5	4,5/13,5	3/9	6-18	7-22
Motor Power	(Kw)	1,1	1,1	1,1	1,1	2,2/2,2/2x1,5	2,2/2,2/2x1,5
Fan Motor Power	(Kw)	0,37/0,37/0,37	0,37/0,37/0,37	0,37/0,37/2x0,37	0,37/0,37/0,75	3/3/0,37+3	3/3/0,37+3
Elec. Heating Power	(Kw)	30	37,5	42	48	72	84
Steam Consumption	(Kg/hour)	65	70	75	80	100	150
Gas Heat Power	(Kcal/hour)	26.350	31.570	35.100	41.250	66.000	82.500
Width	(mm)	2.835/2.995/2.995	3.335/3.425/3.425	3.685/3.870/4.010	3.987/3.987/4.207	4.113/4.113/4.400	4.137/4.137/4.156
Depth	(mm)	1.400/1.450/1.540	1.400/1.450/1.540	1.697/1.697/1.714 (2.260)(2.260)(2.405)	1.564/1.564/1.679	2.038/2.038/2.038 (3.016)(3.016)(3.016)	2.203/2.203/2.079 (3.181) (3.181)(3.057)
Height	(mm)	1.850/1.800/2.170	1.850/1.850/2.170	1.697/1.697/1.714	1.564/1.564/1.679	2.764/2.764/2.247	3.042/3.042/2.971
Weight	(Kg)	1.475	1.600	1.725	1.920	2.525/2.525/2.325	3.990/ 3.990/3.640

Tolkar reserves changing the technical specifications of the machines due to technological necessities without prior notice

Capacities are given for the laundry extracted at 300 G force.

It is recommended that textiles keeping more water and moisture due to thickness or knit raw material should be pre dried in the dryers before ironing.

## VELA CHI

Chest Heated Ironers



Green  
technology



**GAS HEATING**  
OPTION IN ALL MODELS

**HUMIDITY  
DISCHARGE  
VIA INVERTER  
CONTROLLED FANS  
FROM INSIDE  
THE ROLLS**

● SINGLE  
●● DOUBLE  
**ROLLS**



**DIRECT DRIVE  
WITH  
GEAR BOX**



**VELA CHI**  
Chest Heated Ironers

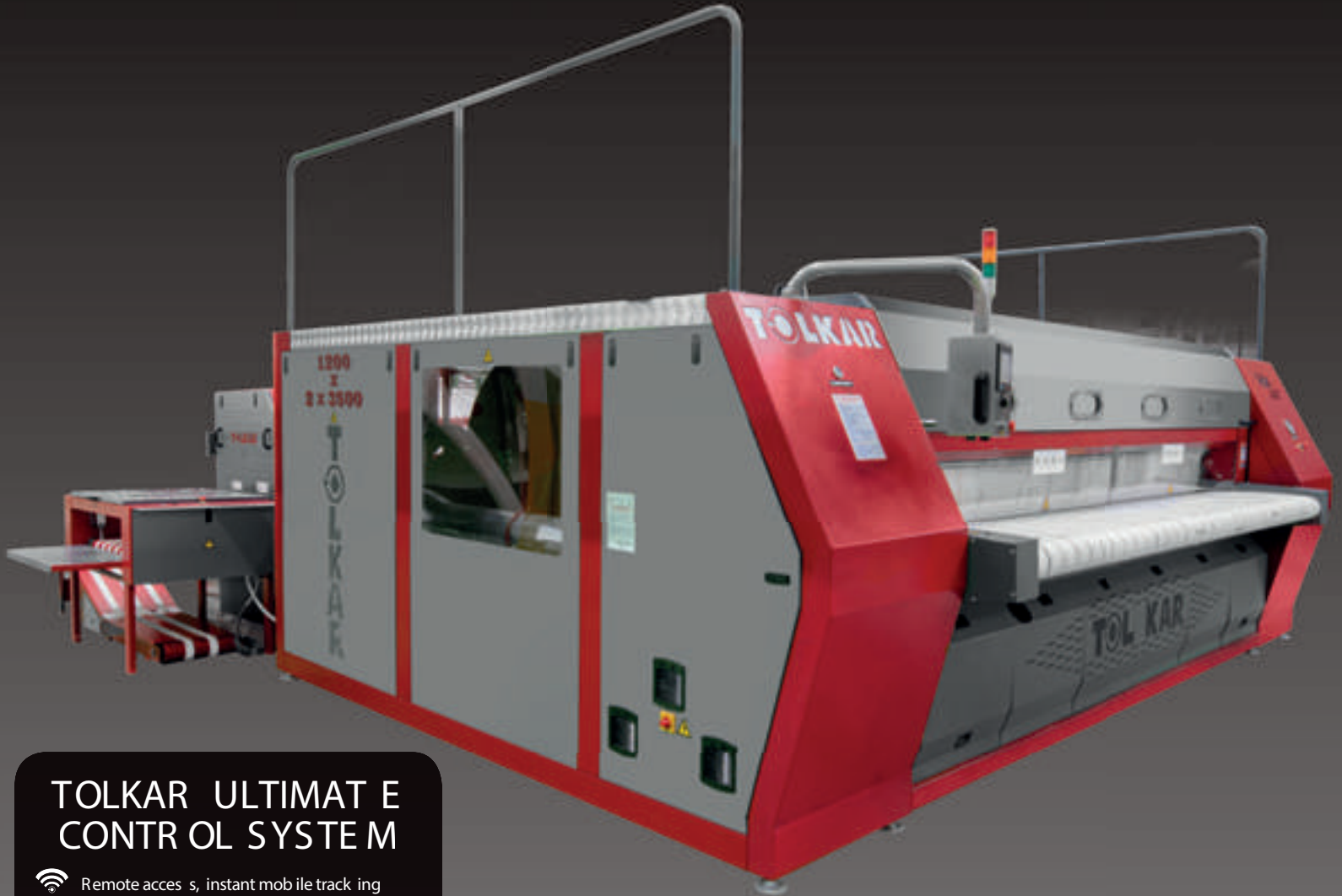

**TOLKAR ULTIMATE CONTROL SYSTEM**

- Remote access, instant mobile tracking
- USB programme transfer
- 5 ready recipes, 100 recipes
- (i) Reporting, amount of laundry, consumption values and working hours are being reported. (Optional)
- Smarteye centralized control and data acquisition (Optional)

  
**PLC Controlled**  
7" Touch Screen Panel

  
ACCORDING TO TEXTILE TYPES  
**VELOCITY CONTROLLED ROLLS**

**HIGH PRESSURE RESIST (12 BAR)**  
**GERMAN MADE CHESTS**

**MAXIMUM PRESSURE & PRESSING**  
Quality via special spring crushes and pneumatic systems

## VELA CHI

Chest Heated Ironers

800 - 1200 mm  
Roll Diameter



		Vela CHI 18030	Vela CHI 28030	Vela CHI 18033	Vela CHI 28033	Vela CHI 18035	Vela CHI 28035
Heating Type		Buh/ Gaz	Buh/ Gaz	Buh/ Gaz	Buh/ Gaz	Buh/ Gaz	Buh/ Gaz
Number of Cylinder	(Pcs.)	1	2	1	2	1	2
Cylinder Diameter	(mm)	800	800	800	800	800	800
Cylinder Width	(mm)	3.000	3.000	3.300	3.300	3.500	3.500
Ironing Capacity	(Kg/hour)	150	350	160	400	180	420
Ironing Capacity	(Pcs./hour)	250	600	275	650	300	700
Working Speed	(m/min)	3-12	6-21	3-12	6-21	3-12	6-21
Motor Power	(Kw)	3	2x3	3	2x3	3	2x3
Fan Motor Power	(Kw)	0,75	1,1	7,5	1,1	7,5	1,1
Gas Heat Power	(Kcal/hour)	66.825	123.750	66.825	123.750	66.825	123.750
Steam Consumption	(Kg/hour)	120	220	130	240	130	240
Width	(mm)	4.338	4.339/4.624	4.638	4.639/4.924	4.838	4.839/5.124
Depth	(mm)	2.139	3.256/3.573	2.139	3.256/3.573	2.139	3.256/3.573
Height	(mm)	1.545 (2.089)	1.545 (2.101)/ 1.581(1.979)	1.545 (2.089)	1.545 (2.101)/ 1.581(1.979)	1.545 (2.089)	1.545 (2.101)/ 1.581(1.979)
Weight	(Kg)	3.700	5.800	3.750	5900	3.850	6000

Tolkar reserves changing the technical specifications of the machines due to technological necessities without prior notice. It is recommended that textiles keeping more water and moisture due to thickness or knit raw material should be pre dried in the dryers before ironing.

## VELA CHI

Chest Heated Ironers

3000 - 3300 - 3500 mm  
Roll Width



Gas Heating System

Chest and Drive System

		Vela CHI 112030	Vela CHI 212030	Vela CHI 112033	Vela CHI 212033	Vela CHI 112035	Vela CHI 212035
Heating Type		Buh/ Gaz	Buh/ Gaz	Buh/ Gaz	Buh/ Gaz	Buh/ Gaz	Buh/ Gaz
Number of Cylinder	(Pcs.)	1	2	1	2	1	2
Cylinder Diameter	(mm)	1.200	1.200	1.200	1.200	1.200	1.200
Cylinder Width	(mm)	3.000	3.000	3.300	3.300	3.500	3.500
Ironing Capacity	(Kg/hour)	250	600	280	660	300	700
Ironing Capacity	(Pcs./hour)	400	1000	450	1100	500	1150
Working Speed	(m/min)	4-18	9-38	4-18	9-38	4-18	9-38
Motor Power	(Kw)	7,5	2x7,5	7,5	2x7,5	7,5	2x7,5
Fan Motor Power	(Kw)	1,5	2,2	2,2	2,2	2,2	2,2
Gas Heat Power	(Kcal/hour)	106.425	200.475	125.400	247.500	125.400	247.500
Steam Consumption	(Kg/hour)	190	360	225	440	225	440
Width	(mm)	4.835/5.075	4.839/5.059	5.135/5.375	5.139/5.359	5.335/5.575	5.339/5.559
Depth	(mm)	2.532/3.036	4.074/4.351	2.532/3.036	4.074/4.351	2.532/3.036	4.074/4.351
Height	(mm)	1.885 (2.366)/ 1.885 (2.371)	1.885 (2.225)/ 1.885 (2.225)	1.885 (2.366)/ 1.885 (2.371)	1.885 (2.225)/ 1.885 (2.225)	1.885 (2.366)/ 1.885 (2.371)	1.885 (2.225)/ 1.885 (2.225)
Weight	(Kg)	4.400	9.200	4.500	9.500	4.600	9.900

Tolkar reserves changing the technical specifications of the machines due to technological necessities without prior notice

It is recommended that textiles keeping more water and moisture due to thickness or knit raw material should be pre dried in the dryers before ironing.

**CAMILA MEGGY**  
Chest Heated Ironers



**Small Piece Automatic Collection and Stacking System (Optional)**

**Conveyor and Stacker**

**Photocell Aided Sensitive Textiles Measurement**

**Automatic Speed Synchronization In Between Ironing and Folding**

**Height Adjustable and Vacuumed Feeding Conveyor**

  
**3 Primary and 3 Cross Folds**

**DOUBLE LANE FOLDING**

  
**GAS HEATED**

  
**PLC Controlled 10 inch Touch Screen Panel**

**MEGGY**  
Chest Heated Ironers



**Maximum Ironing Quality with Double Sided Contact In Between The Chests and Textiles**

**Engineered Pass System In Between Chests Without Stripes & Ribbons**

**Engineered Convex Type Chest System**

		<b>Camila Meggy</b>
<b>Heating Type</b>		<b>Gas</b>
Number Of Chests	(Pcs.)	<b>2</b>
Chest Diameter	(mm)	<b>2x800</b>
Ironing Width	(mm)	<b>3.500</b>
Ironing Capacity	(Kg/hr)	<b>280-320</b>
Ironing Capacity	(Pcs/hr)	<b>350-400</b>
Ironing Speed	(m/min)	<b>4-18</b>
Motor Power	(Kw)	<b>9,34</b>
Fan Power	(Kw)	<b>2 x 1,5</b>
Gas Heating Power	(Kcal/hr)	<b>99.000</b>
Width	(mm)	<b>4.383 (6.110)</b>
Depth	(mm)	<b>4.166</b>
Height	(mm)	<b>2.645</b>
Weight	(Kg)	<b>9.350</b>

**1 lane / 1-2-3 primary fold  
1-2-3 cross fold  
2 lanes / 1-2 primary fold  
1-2 cross fold  
3 lanes / 1-2-3 primary fold**

**Minimum Maintenance With Ribbon Free & Crush Springs Free Engineered Design**

**Air Regulator and Automatic Air Discharge System**

## VIRGO

Linen Folding

3000 - 3300 - 3500 mm  
Width

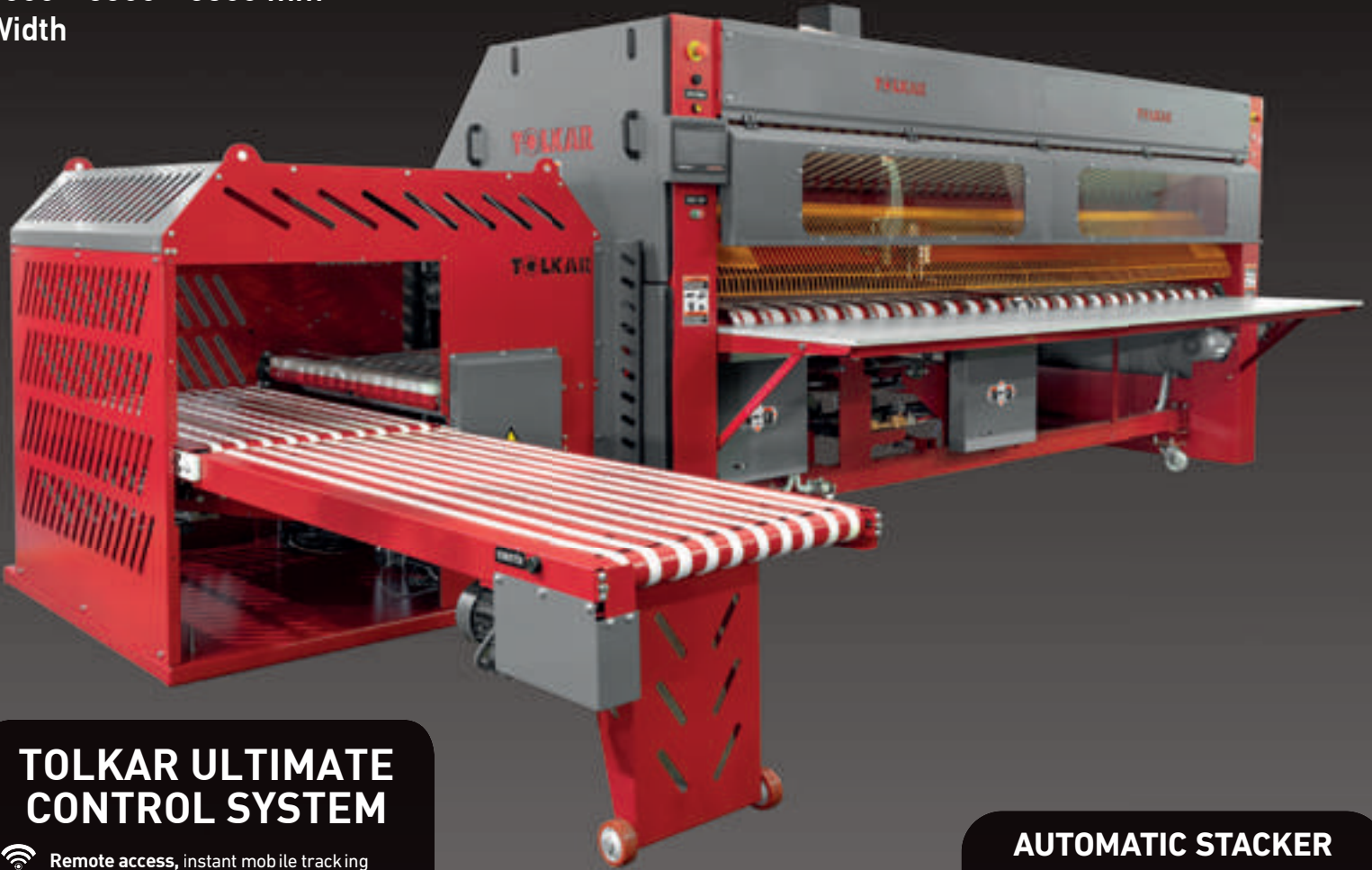

### TOLKAR ULTIMATE CONTROL SYSTEM

- Remote access, instant mobile tracking
- USB programme transfer
- 100 recipes
- Reporting**, amount of laundry, consumption values and working hours are being reported. (Optional)
- **Smarteye** centralized control and data acquisition (Optional)

**AUTOMATIC SPEED SYNCHRONIZATION WITH IRONER**

**AUTOMATIC STACKER AND CONVEYOR**  
for easy handling  
double stacker & conveyor  
(Optional)

**Single lane**  
**2 primary**  
**3 cross folds**

Double lane 2 primary  
2 cross folds and stacking  
(linen, f&b) (Optional)

4 lanes, 2 primary folds  
(f&b) (Optional)

Blanket and duvet folding  
(Optional)

**PLC Controlled**  
**7" Touch Screen Panel**

	VIRGO 3000	VIRGO 3300	VIRGO 3500
--	------------	------------	------------

Folding Capacity	(Pcs/hour)	1.800	1.800	1.800
Working Speed	(m/min)	12-60 adjustable		
Folding Dimensions	(cm)	40x40 - 300x350		
Motor Power (Total)	(Kw)	3	3	3
Primary/Cross Folding		2 primary/3 cross		
Width	(mm)	3.710(5.034)	4.010(5.334)	4.210(5.534)
Depth	(mm)	1.757	1.757	1.757
Height	(mm)	3.894	3.894	3.894
Weight (Conveyor included)	(Kg)	1.750	2.050	2.200

Tolkar reserves changing the technical specifications of the machines due to technological necessities without prior notice

**VIRGO**  
Towel Folding



**PLC  
Controlled  
7" Touch Screen  
Panel**

**4 SPLIT INPUT  
CONVEYOR**

Ability to fold

**120x200 cm**

**ABILITY TO  
FOLD AND SPLIT  
ALL TOWEL GROUPS  
AUTOMATICALLY**

**TOLKAR ULTIMATE  
CONTROL SYSTEM**

**FOLDING WITH AIR BLAST**

- Remote access**, instant mobile tracking
- USB programme transfer**
- 100 recipes**
- Reporting**, amount of laundry, consumption values and working hours are being reported. (Optional)
- SmarteYE** centralized control and data acquisition (Optional)

**HEIGHT ADJUSTABLE  
INPUT CONVEYOR AND  
DOUBLE OUTPUT FLAP**

Folding Capacity	(Pcs/hour)	<b>900 - 1.000</b>
Working Speed	(m/min)	<b>64</b>
Folding Dimensions	(cm)	<b>40x40 - 120x200</b>
Motor Power (Total)	(Kw)	<b>2</b>
Primary/Cross Folding		<b>2 en/2 boy</b>
Width	(mm)	<b>2.996</b>
Depth	(mm)	<b>5.200</b>
Height	(mm)	<b>1.408</b>
Weight (Conveyor included)	(Kg)	<b>1.485</b>

Tolkar reserves changing the technical specifications of the machines due to technological necessities without prior notice

## VIRGO SMARTFOLD

Towel Folding



**Ergonomic Stacking To Top Side Of The Machine**

**120x200 cm**  
Folding



PLC  
Controlled  
7 inch Touch  
Screen Panel

**ABILITY TO FOLD AND SPLIT  
ALL TOWEL GROUPS  
AUTOMATICALLY**

**3 Split  
Input Conveyor**

**Enhanced Flat  
Primary Folding  
System With  
Blades**

**Engineered Cross  
Folds Via Pistons  
or Air Blast  
Depending On The  
Textile Thickness**

**Engineered Cross  
Fold Transportation  
System By Automatic  
Customizable Textile  
Thickness**

### TOLKAR ULTIMATE CONTROL SYSTEM

- Remote access, instant mobile tracking
- USB programme transfer
- 100 recipes
- Reporting**, amount of laundry, consumption values and working hours are being reported. (Optional)
- Smarteye centralized control and data acquisition (Optional)

Folding Capacity	(Pcs./hour)	900 - 1.000
Working Speed	(m/min)	54
Folding Dimensions	(cm)	40x40 - 120x200
Motor Power (Total)	(Kw)	2,75
Primary/Cross Folding		2 / 2
Width	(mm)	1.815
Depth	(mm)	3.565
Height	(mm)	1.775
Weight	(kg)	1.400

Tolkar reserves changing the technical specifications of the machines due to technological necessities without prior notice



**VIRGO MAXX**  
Towel Folding



**PLC  
Controlled  
7" Touch Screen  
Panel**

**ABILITY TO  
FOLD AND SPLIT  
ALL TOWEL GROUPS  
AUTOMATICALLY**

**1 SPLIT INPUT  
CONVEYOR**

with ability to fold up to

**120x240 cm**

**TOLKAR ULTIMATE  
CONTROL SYSTEM**

- Remote access**, instant mobile tracking
- USB programme transfer**
- **100 recipes**
- Reporting**, amount of laundry, consumption values and working hours are being reported. (Optional)
- **SmarteYE** centralized control and data acquisition (Optional)

Folding Capacity	(Pcs./hour)	<b>700 - 900</b>
Working Speed	(m/min)	<b>30</b>
Folding Dimensions	(cm)	<b>40x40 - 120x240</b>
Motor Power (Total)	(Kw)	<b>0,61</b>
Primary/Cross Folding		<b>1 / 2</b>
Width	(mm)	<b>1.550</b>
Depth	(mm)	<b>3.940</b>
Height	(mm)	<b>1.450</b>
Weight	(kg)	<b>1.505</b>

Tolkar reserves changing the technical specifications of the machines due to technological necessities without prior notice

## VIRGO

Napkin, Pillow Case Stacker

- Flat stacking ability for small pieces such as napkins, runners, pillow cases on 4 separate lines
- Requested number of stacked textiles are collected by only
- 1 operator instead of 4
- PLC based 7" touch screen panel
- 30 meters/min working speed
- Maximum stacking dimensions 3000-3300-3500 width options
- 100 programmes
- Separate programming for each 4 lanes
- Reporting based on textile types and numbers
- Reporting based on programme and lanes
- Automatic speed synchronization with chest heated ironers and folding machines
- By pass option for large items



		VIRGO 3000	VIRGO 3300	VIRGO 3500
Working Speed	(m/min)	12-30	12-30	12-30
Capacity	(Pcs./hour)	3.600	3.600	3.600
Air Consumption	(lt/min)	540 (6-8 bar)	540 (6-8 bar)	540 (6-8 bar)
Motor Power	(Kw)	1,5	1,5	1,5
Stacking Dimensions	(cm)	72x55	80x55	85x55
Nr. of Split Input Conveyors		4	4	4
Width	(mm)	3.480	3.780	3.980
Depth	(mm)	3.530	3.530	3.530
Height	(mm)	1.650	1.650	1.650

## VIRGO

Vacuum Feeder

### 3000 - 3300 - 3500 mm Width

#### Standard Features

- Vacuum Feeders are designed for huge capacity ironers in order to perform the most demanding high quality finishing tasks. It is suitable for linens, pillow cases, table napkins and table clothes.
- Ergonomic designed structure with high efficient centrifugal fans, a forceful airflow has created to catch, to flatten, to tauten and to feed the laundry.
- All movements such as string, bending, pulling fulfilled by operators normally, are done mechanically in order to achieve dramatically savings.
- Besides by reducing the gap of fed linens in between, efficiency of the ironer has been raised up.
- According to type of fed material, speed and vacuuming are adjustable whereas feeder relocates easily with carrier wheels.



		VIRGO 3000	VIRGO 3300	VIRGO 3500
Feeder Weight	(mm)	3.000	3.300	3.500
Working Speed	(m/min.)	6 - 36 adjustable	6 - 36 adjustable	6 - 36 adjustable
Motor Power (Total)	(Kw)	0,55	0,55	0,55
Fan Motor Power	(Kw)	4x0,75	4x0,75	4x0,75
Width	(mm)	3.463	3.763	3.963
Depth	(mm)	1.252	1.252	1.252
Height	(mm)	1.273	1.273	1.273
Weight	(Kg)	760	820	880

**AUTOMATIC SPEED SYNCHRONIZATION WITH IRONING**

Tolkar reserves changing the technical specifications of the machines due to technological necessities without prior notice



**VIRGO**  
Towel Roller

Feeding Range	(mm)	<b>650</b>
Width	(mm)	<b>935</b>
Depth	(mm)	<b>820</b>
Depth	(mm)	<b>535</b>
Height	(mm)	<b>140</b>

**Standard Features**

- Compact and easy usage
- 200-300 pcs/hour capacity
- Bottom Shelf (Optional)

**AUXILIARY EQUIPMENTS**



**Garment Conveyor**



**Packing Machine**



**Mobile Hanger Trolley**



**Single / Double Sink Unit**  
Stainless Steel  
(90-120-140-160-180-190 cm)



**Mobile Working Table**  
Stainless Steel  
(90-140-180-190-240-290 cm)



**Laundry Trolley**  
(270-280-500-900-1000-2000 liters)



**Stainless Steel Shelves**  
(90-120-140-160-180-190 cm)

## AUXILIARY EQUIPMENTS

- Tolkar Dry Cleaning Machines
- Presses
- Narrow Type Ironing Tables
- Air Form Finishers
- Stain Removers
- Shirt Robots And Collar & Cuff Presses
- Trolleys
- Mobile Working Tables
- Shelves
- Sink Units
- Garment Hanger Trolleys
- Marking Machines
- Packing Machines
- Conveyor Systems
- Steam Generators
- Air Compressors
- Sewing And Overlook Machines

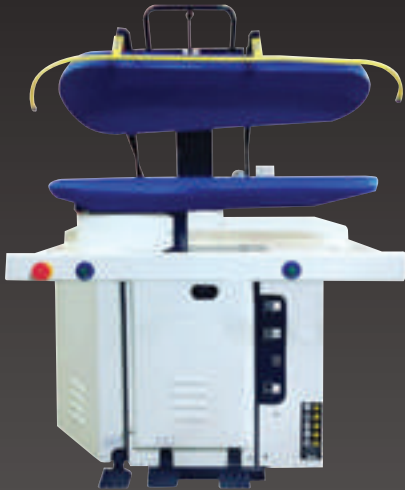

**Pressing Machine**  
Manual / Pneumatic  
Electric / Steam Heated

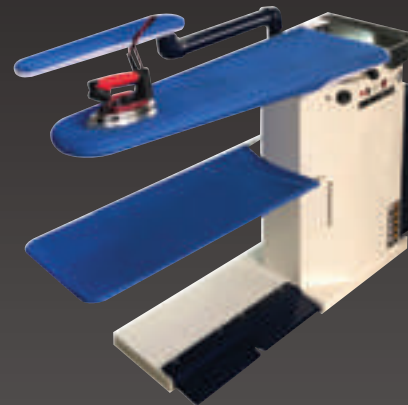

**Narrow Type Ironing Table**  
Electric / Steam Heated

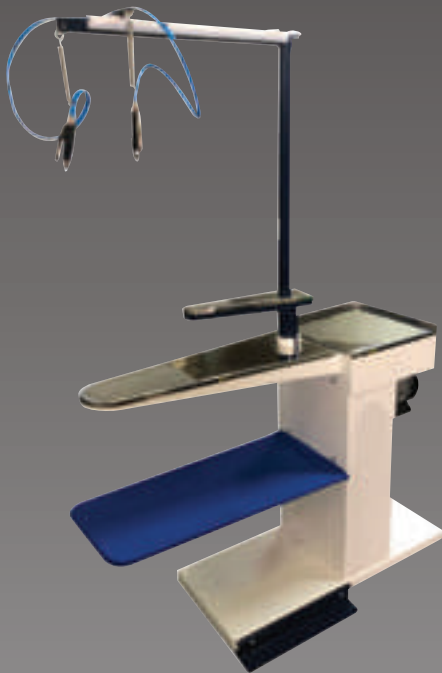

**Stain Removal / Spotting Machine**  
Electric / Steam Heated



**Air Form Finisher**  
Manual / Pneumatic  
Electric / Steam Heated

**COLMAC**  
Automatic Tunnel Finisher



		CFS 300	CFS 600	CFS 900	CFS 1200	CFS 2100
Heating Type		Steam/Gas	Steam/Gas	Steam/Gas	Steam/Gas	Steam/Gas
Workwear						
%30 Humidity Retention	Pcs./Hour	150	200	300	450	700
%35 Humidity Retention	Pcs./Hour	130	150	255	385	600
%40 Humidity Retention	Pcs./Hour	110	130	220	335	525
%45 Humidity Retention	Pcs./Hour	100	150	200	300	465

**Minimized labour and maximized productivity with continous system**

**Front to rear air flow**

**Maximum wrinkle free operation with active steam jets**

**Most advanced uniform ironing system**

**The most effective uniform ironing system**

**Stainless steel tunnel construction**

**Adjustable speed**

**PLC Controlled 7" Touch Screen Panel**

## TUNNEL WASHING SYSTEMS



## DISTRIBUTORSHIPS



**Speed Queen®**

 **COLMAC**

 **RENZACCI**



## **COUNTRIES WE ARE EXPORTING TO**

Afganistan	Kosovo
Albania	Kyrgyzstan
Algeria	Lebanon
Armenia	Libya
Aruba	Macedonia
Azerbaijan	Madagascar
Bangladesh	Maldives
Belarus	Mauritius
Belgium	Mexico
Bosna Herzigova	Morocco
Bulgaria	Netherlands
China	Norway
Colombia	Oman
Croatia	Pakistan
Denmark	Phillippines
Dominican Republic	Poland
Egypt	Portugal
Egypt	Qatar
England	Romania
Estonia	Russia
Ethiopia	Rwanda
France	Saudi Arabia
Georgia	Serbia
Germany	Slovakia
Ghana	South Africa
Greece	Spain
Greenland	Sri Lanka
Hungary	Sudan
India	Sweden
Indonesia	Syria
Iran	Tanzania
Iraq	Tunisia
Ireland	Tunisia
Israel	Turkmenistan
Italy	UAE
Jordan	Ukraine
Kazakhstan	USA
Kenya	Uzbekistan
Korea	Vietnam

[info@gvhts.com](mailto:info@gvhts.com)

[www.gvhts.com](http://www.gvhts.com)

**TOLKAR®**  
**SMARTEX®**  
Technological, Economical, Ecological Differences



**GATEWAY**

P6-71, SAIF Zone,  
Sharjah, United Arab Emirates  
Tel: +971 6 5573850 | Fax: +971 6 5573851

[www.gvhts.com](http://www.gvhts.com)

[info@gvhts.com](mailto:info@gvhts.com)



01/2023